

 **PIONEER®**

# Service Manual

**CIRCUIT & MECHANISM  
DESCRIPTIONS**

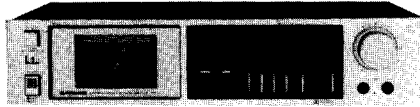

The photo shows the model CT-720.

**ORDER NO.  
ARP-003-0**

**STEREO CASSETTE TAPE DECK**

# CT-720

# CT-520

# CT-320

- This Service Manual should be used together with the Service Manual <ARP-001-0> for CT-6R and 7R, and <ARP-002-0> for CT-4 and 5.

# 1. CT-720

## Block Diagram

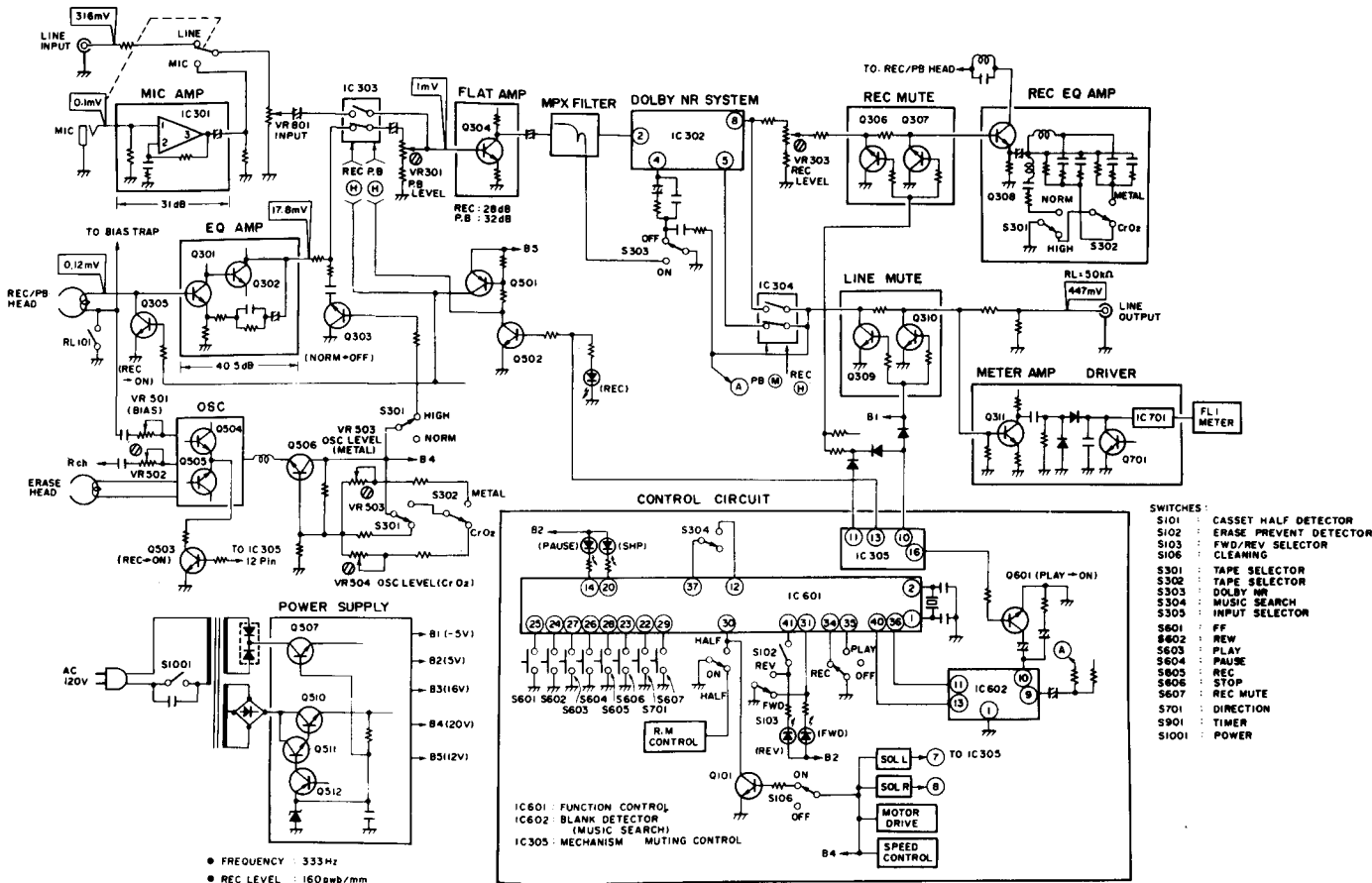

Refer to the block diagram for circuit details.

### 1.1 SIGNAL PATHS

#### Playback Mode

The signal from the REC/PB head is passed via the equalizer amplifier (Q301/Q302), a bilateral switch (IC303), a flat amplifier (Q304) and MPX filter to the Dolby NR processor (pin 2 of HA11226). The Dolby NR processor output (pin 8 of HA11226) is applied to the LINE OUTPUT via another bilateral switch (IC304) and the line muting circuit (Q309/Q310).

#### Recording Mode

The LINE INPUT signal or MIC signal (mic amplifier output) is passed to the Dolby NR processor (pin 2 of HA11226) via the INPUT level control (VR801), a bilateral switch (IC303), a flat amplifier (Q304) and MPX filter.

The Dolby NR processor output (pin 8 of HA11226) is applied to the REC/PB head via the REC muting circuit (Q306/Q307), the recording amplifier (Q308) and a bias trap.

- For Mechanism Descriptions, refer to the Service Manual (CIRCUIT & MECHANISM DESCRIPTIONS) <ARP-001-0> for CT-6R and 7R.

## 2. CT-520

### Block Diagram

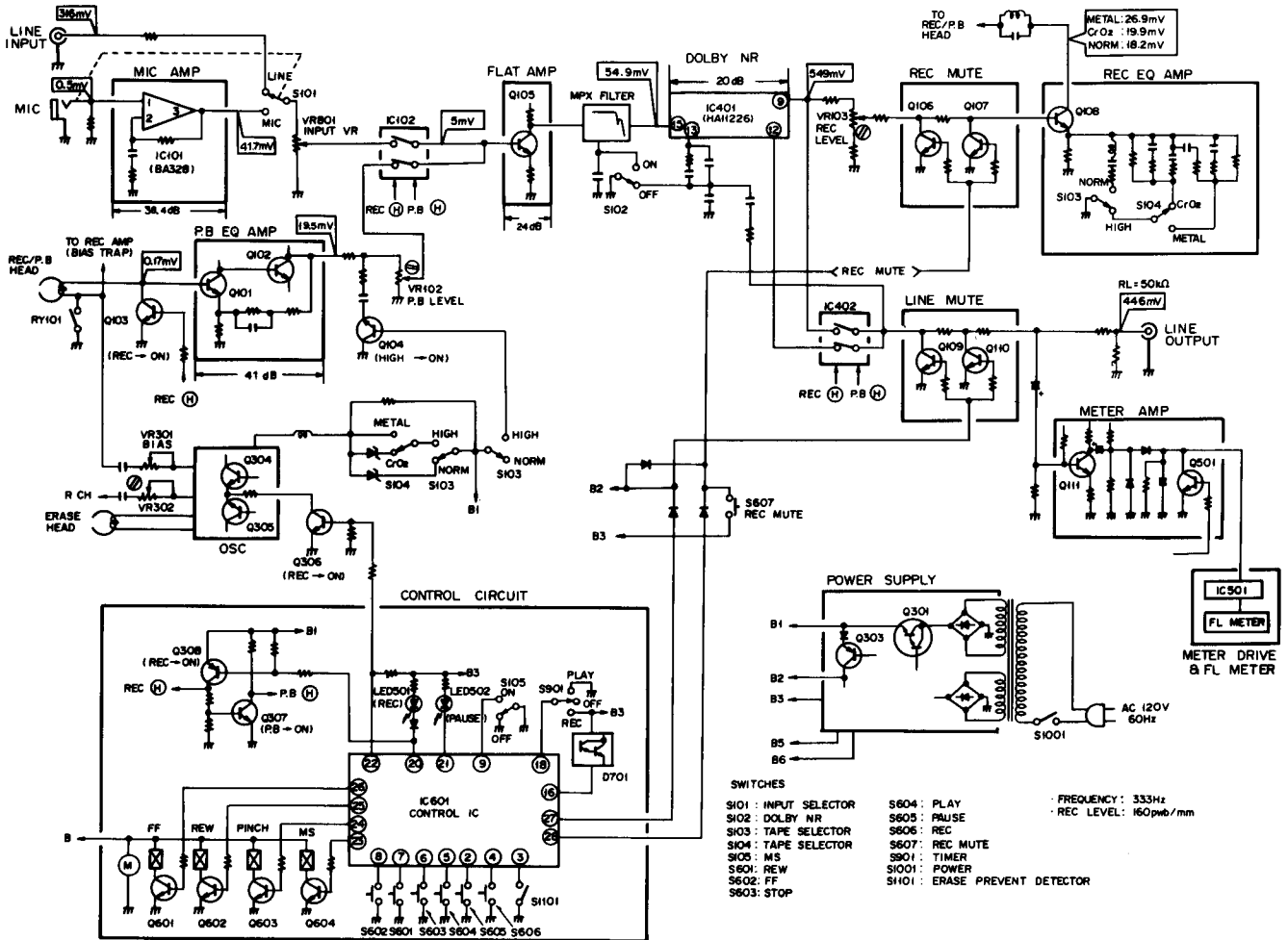

Refer to the block diagram for circuit details.

### 2.1 SIGNAL PATHS

#### Playback Mode

The signal from the REC/PB head is passed via the equalizer amplifier (Q101/Q102), a bilateral switch (IC102), flat amplifier (Q105) and MPX filter before being applied to the Dolby NR processor (pin 15 of HA11226). The Dolby NR processor output (pin 9 of HA11226) is then passed via another bilateral switch (IC402) and the line muting circuit (Q109/Q110) to the LINE OUTPUT.

#### Recording Mode

The LINE INPUT signal or MIC signal (output from the MIC amplifier) is passed via the INPUT level control (VR801), a bilateral switch (IC102), a flat amplifier (Q105) and MPX filter to the Dolby

NR processor (pin 15 of HA11226). The Dolby NR processor output (pin 9 of HA11226) is then passed to the REC/PB head via the REC mute circuit (Q106/Q107), recording amplifier (Q108) and bias trap.

- Control circuit and Mechanism Descriptions are basically the same as those in CT-5. Refer to pages 4 through 9 of the Service Manual (CIRCUIT & MECHANISM DESCRIPTIONS) <ARP-002-0> for CT-4 and 5.

### 3. CT-320

#### Block Diagram

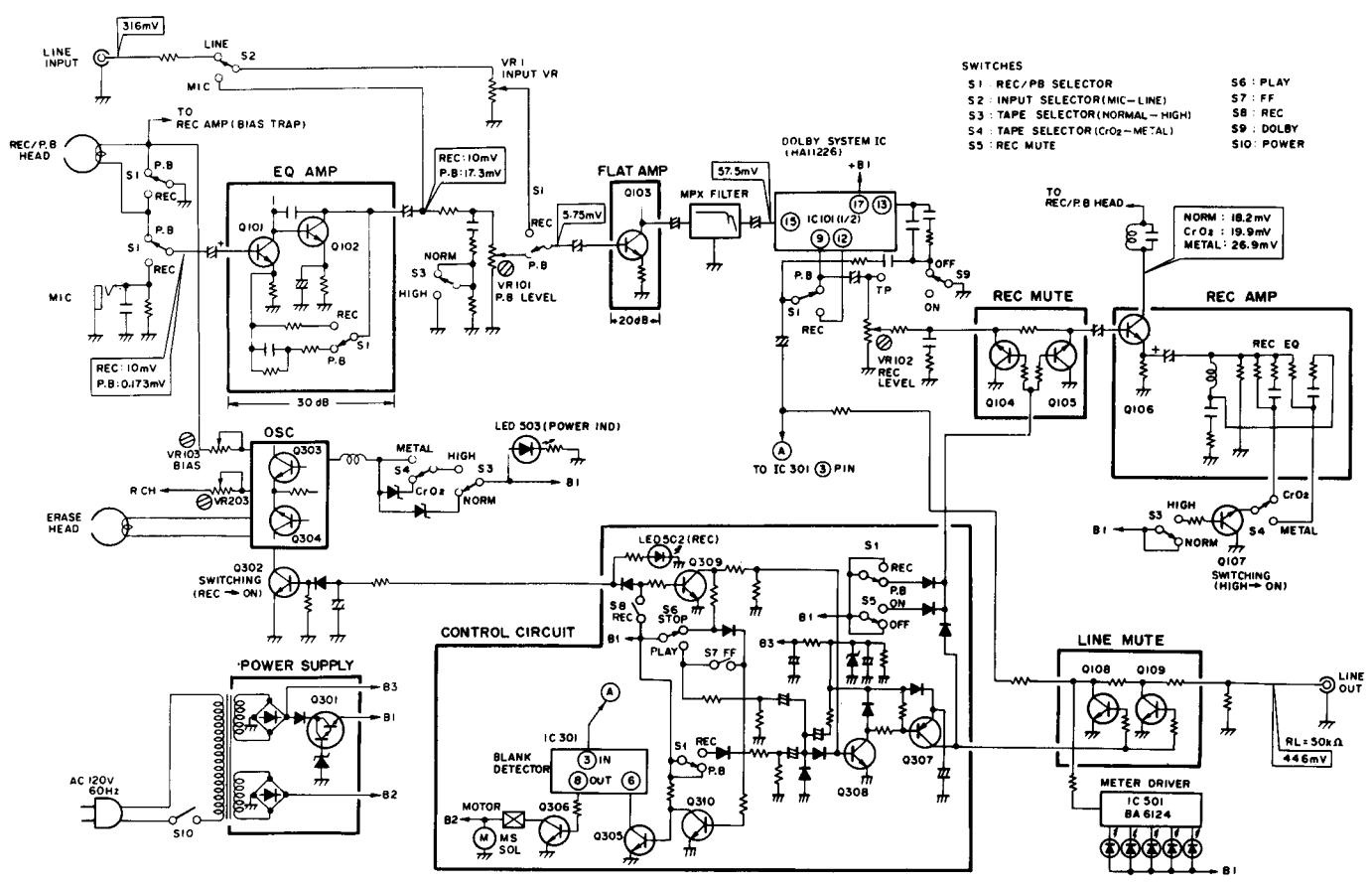

Refer to the block diagram for circuit details.

#### 3.1 SIGNAL PATHS

##### Playback Mode

The signal from the REC/PB head is passed via the equalizer/mic amplifier (Q101/Q102) and flat amplifier (Q103) to the Dolby NR processor (pin 15 of HA11226). The Dolby NR processor output (pin 9 of HA11226) is applied to the LINE OUTPUT via the line muting circuit (Q108/Q109).

##### Recording Mode

The LINE INPUT signal is passed via the INPUT SELECTOR switch (S2), the INPUT level control (VR1), a flat amplifier (Q103), the MPX filter and finally to the Dolby NR processor (pin 15 of HA11226).

The MIC output signal, on the other hand, is passed to the equalizer/mic amplifier (Q101/Q102) before being passed to the INPUT SELECTOR switch (S2), the INPUT level control (VR1),

flat amplifier (Q103), MPX filter switch and Dolby NR processor (pin 15 of HA11226). The Dolby NR processor output (pin 9 of HA11226) is passed to the REC muting circuit (Q104/Q105), recording amplifier (Q106), bias trap and REC/PB head.

- **MUTING circuit, MUSIC SEARCH and Mechanism** Descriptions are basically the same as those in CT-4. Refer to pages 11 through 21 of the Service Manual (CIRCUIT & MECHANISM DESCRIPTION) <ARP-002-0> for CT-4 and 5.